

PRODUCT INFORMATION PACKET

Modal No: 048A11T198
Catalog No: X303
1/4,1075,TEAO,48Y,1/60/115
Direct Drive Blower and Unit Heater



Regal and Marathon are trademarks of Regal Beloit Corporation or one of its affiliated companies.

©2017 Regal Beloit Corporation, All Rights Reserved. MC017097E



Nameplate Specifications

Output HP	0.25 Hp	Output KW	0.19 kW
Frequency	60 Hz	Voltage	115 V
Current	4.1 A	Speed	1075 rpm
Service Factor	1	Phases	1
Efficiency	59.5 %	Duty	CONTINUOUS
Insulation Class	B	Design Code	NO DESIGN CODE
KVA Code	D	Frame	48Z
Enclosure	TEAO	Overload Protector	AUT LCK RTR ONLY
Ambient Temperature	40 °C	Drive End Bearing Size	6203
Opp Drive End Bearing Size	6203	UL	Recognized
CSA	Y	CE	N
IP Code	43		

Technical Specifications

Electrical Type	PSC 1 SPEED	Starting Method	ACROSS THE LINE
Poles	6	Rotation	SELECTIVE CCW
Mounting	RESILIENT BASE-EXTENDED STUDS	Motor Orientation	HORIZONTAL
Drive End Bearing	BALL	Opp Drive End Bearing	BALL
Frame Material	ROLLED STEEL	Shaft Type	SGL SPL EXT
Overall Length	8.5 in	Frame Length	4.25 in
Shaft Diameter	0.5 in	Shaft Extension	2.81 in
Assembly/Box Mounting	F1 ONLY		

SS74126

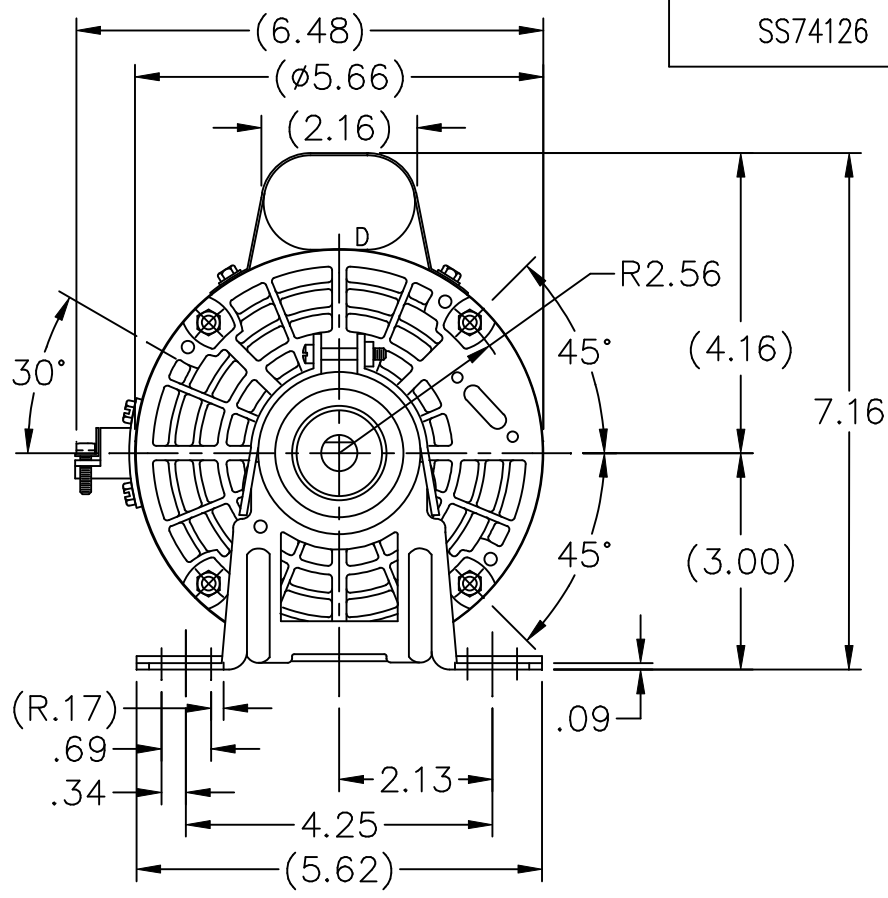
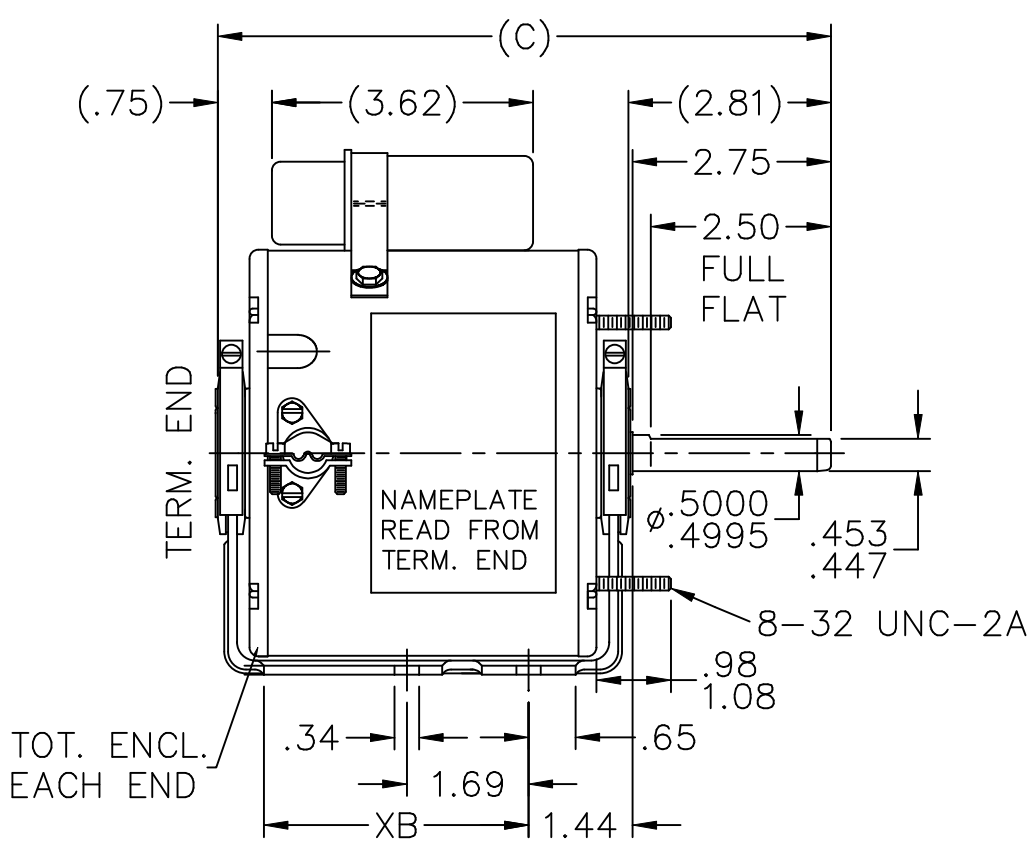

LEAD DESCRIPTION:
 1 BLACK AND 1 WHITE LEAD WITH .50 BARE WIRE STRIP EXIT MOTOR THROUGH CONDUIT CONNECTOR WITH ADJUSTABLE THROAT OPENING. 35.00-37.00" LONG PURPLE AND YELLOW REVERSING LEADS MOLDED INTO MATING PULL-APART PLUGS. 4.00-6.00 LONG.

DASH	C	XB
425	8.50	3.67
475	9.00	4.17

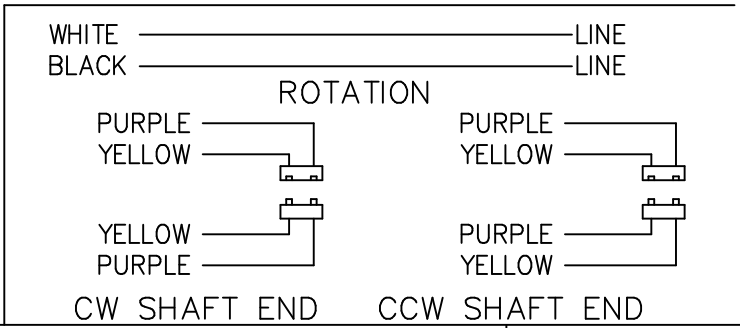

NO.	REVISION	BY & DATE	CHK	TOLERANCES UNLESS SPECIFIED	
				DEC.	INCHES
				.X	±.1
4	REVISED MOUNTING HOLE LOCATIONS	RJW 07-12-2005	ML	.XX	±.03
3	REDRAWN IN AUTOCAD	TAT 05-19-2005	ML	.XXX	±.005
2	REDRAWN ON CADD - NO CHANGE	MRB 04-01-1998		.XXXX	±.0005
			CHG	ANG	±7'30"



DRAWN MRB 03-10-1998
CHK ML 04-01-1998
APPD GK 04-01-1998
SCALE 3=8
REF
FMF
PREV

THIS DRAWING IN DESIGN AND DETAIL IS OUR PROPERTY AND MUST NOT BE USED EXCEPT IN CONNECTION WITH OUR WORK ALL RIGHTS OF DESIGN AND INVENTION ARE RESERVED THIS IS AN ELECTRONICALLY GENERATED DOCUMENT - DO NOT SCALE THIS PRINT	RFP	CAD FILE ss74126	SIZE A	DRAWING NO. SS74126	PAGE OF	REV. 4
	DIST WP					

```
ERROR: syntaxerror  
OFFENDING COMMAND: --nostringval--
```

```
STACK:
```

```
/initialize  
-dictionary-  
/Pscript_WinNT_Compact  
-dictionary-
```

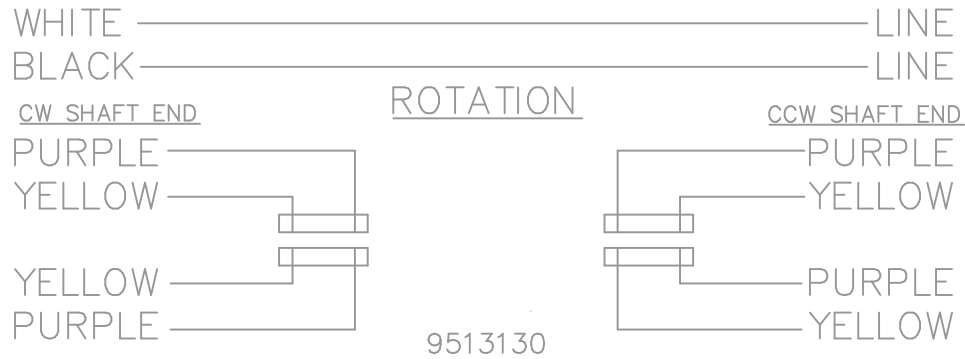

				TOLERANCES UNLESS SPECIFIED			DRAWN TOM 09/19/1988		
				DEC.	INCHES		CHK		
				.X	±.1		APPD MS 09/20/1988		
				.XX	±.02		SCALE 1=1		
				.XXX	±.005		REF		
3	REDRAWN IN AUTOCAD	JMS 03/11/2005		.XXX	±.005	TITLE CONNETION DIAGRAM			
2	NEW DRAWING	TOM 09/19/1988		.XXXX	±.0005	MAT'L.			
NO.	REVISION	BY & DATE	CHK	ANG	±7'30"	FINISH			
THIS DRAWING IN DESIGN AND DETAIL IS OUR PROPERTY AND MUST NOT BE USED EXCEPT IN CONNECTION WITH OUR WORK ALL RIGHTS OF DESIGN AND INVENTION ARE RESERVED THIS IS AN ELECTRONICALLY GENERATED DOCUMENT - DO NOT SCALE THIS PRINT				RFP	CAD FILE 9513130		SIZE	DRAWING NO. PAGE OF	REV.
				DIST	WP	A	9513130	3	

CERTIFICATION DATA SHEET

Model#: 48A11T198 K WINDING#: PE486771 NONE 1
 CONN. DIAGRAM: 9513130 ASSEMBLY: F1 ONLY
 OUTLINE: A-SS74126-425

TYPICAL MOTOR PERFORMANCE DATA

HP	KW	SYNC. RPM	F.L. RPM	FRAME	ENCLOSURE	KVA CODE	DESIGN
1/4	0.19	1200	1075	48Z	TEAO	D	NO DESIGN CODE

PH	Hz	VOLTS	FL AMPS	START TYPE	DUTY	INSL	S.F	AMB°C	ELEVATION
1	60	115	4.1	ACROSS THE LINE	CONTINUOUS	B3	1.0	40	3300

FULL LOAD EFF: 59.5	3/4 LOAD EFF: -	1/2 LOAD EFF: -	GTD. EFF	ELEC. TYPE	NO LOAD AMPS
FULL LOAD PF: 81.5	3/4 LOAD PF: -	1/2 LOAD PF: -	-	PSC 1 SPEED	1.8

F.L. TORQUE	LOCKED ROTOR AMPS	L.R. TORQUE	B.D. TORQUE	F.L. RISE°C
18.9 LB-FT	8.1	5.53 LB-FT -	27.7 LB-FT -	-

SOUND PRESSURE @ 3 FT.	SOUND POWER	ROTOR WK^2	MAX. WK^2	SAFE STALL TIME	STARTS /HOUR	APPROX. MOTOR WGT
- dBA	- dBA	- LB-FT^2	- LB-FT^2	- SEC.	-	- LBS.

*** SUPPLEMENTAL INFORMATION ***

DE BRACKET TYPE	ODE BRACKET TYPE	MOUNT TYPE	ORIENTATION	SEVERE DUTY	HAZARDOUS LOCATION	DRIP COVER	SCREENS	PAINT
STANDARD	STANDARD	RESILIENT BASE-EXTENDED STUDS	HORIZONTAL	FALSE	NONE	FALSE	NONE	GRAY (POWDER)

BEARINGS		GREASE	SHAFT TYPE	SPECIAL DE	SPECIAL ODE	SHAFT MATERIAL	FRAME MATERIAL
DE	OPE						
BALL	BALL	BEACON 325	SGL SPL EXT	0.500 x 2.75 IN SEF WITH 2.50 IN FULL FLAT	NONE	1144 STRESSPROOF (C-223)	ROLLED STEEL
6203	6203						

THERMO-PROTECTORS				THERMISTORS	CONTROL	SPACE /n HEATERS
THERMOSTATS	PROTECTORS	WDG RTDs	BRG RTDs			
NONE	AUT LCK RTR ONLY	NONE	NONE	NONE	FALSE	NONE VOLTS

If Inverter equals NONE, contact factory for further information

*
N
O
T
E
S
*

INVERTER TORQUE: NONE
INV. HP SPEED RANGE: NONE
ENCODER: NONE
NONE NONE
NONE NONE PPR
BRAKE: NONE NONE
NONE P/N NONE
NONE NONE
NONE FT-LB NONE V NONE Hz

Uncontrolled Copy

** Subject to change without notice.