

# PRODUCT INFORMATION PACKET

Modal No: 048C17D2043  
Catalog No: B314  
1/3,1725,DP,48Z,1/60/115/208-230  
Fan and Blower



Regal and Marathon are trademarks of Regal Beloit Corporation or one of its affiliated companies.  
©2017 Regal Beloit Corporation, All Rights Reserved. MC017097E



## Nameplate Specifications

Output HP	<b>0.33 Hp</b>	Output KW	<b>0.25 kW</b>
Frequency	<b>60 Hz</b>	Voltage	<b>115/208-230 V</b>
Current	<b>5.8/3.1-2.9 A</b>	Speed	<b>1725 rpm</b>
Service Factor	<b>1.35</b>	Phases	<b>1</b>
Efficiency	<b>64 %</b>	Duty	<b>CONTINUOUS</b>
Insulation Class	<b>B</b>	Design Code	<b>NO DESIGN CODE</b>
KVA Code	<b>J</b>	Frame	<b>48Z</b>
Enclosure	<b>DP</b>	Overload Protector	<b>NOT</b>
Ambient Temperature	<b>40 °C</b>	Drive End Bearing Size	<b>6203</b>
Opp Drive End Bearing Size	<b>6203</b>	UL	<b>Recognized</b>
CSA	<b>Y</b>	CE	<b>N</b>
IP Code	<b>22</b>		

## Technical Specifications

Electrical Type	<b>CAP START IND RUN</b>	Starting Method	<b>ACROSS THE LINE</b>
Poles	<b>4</b>	Rotation	<b>SELECTIVE CCW</b>
Mounting	<b>RESILIENT RING-EXTENDED STUDS</b>	Motor Orientation	<b>HORIZONTAL</b>
Drive End Bearing	<b>BALL</b>	Opp Drive End Bearing	<b>BALL</b>
Frame Material	<b>ROLLED STEEL</b>	Shaft Type	<b>SGL SPL EXT</b>
Overall Length	<b>10.22 in</b>	Frame Length	<b>6.25 in</b>
Shaft Diameter	<b>0.5 in</b>	Shaft Extension	<b>1.97 in</b>
Assembly/Box Mounting	<b>F1 ONLY</b>		

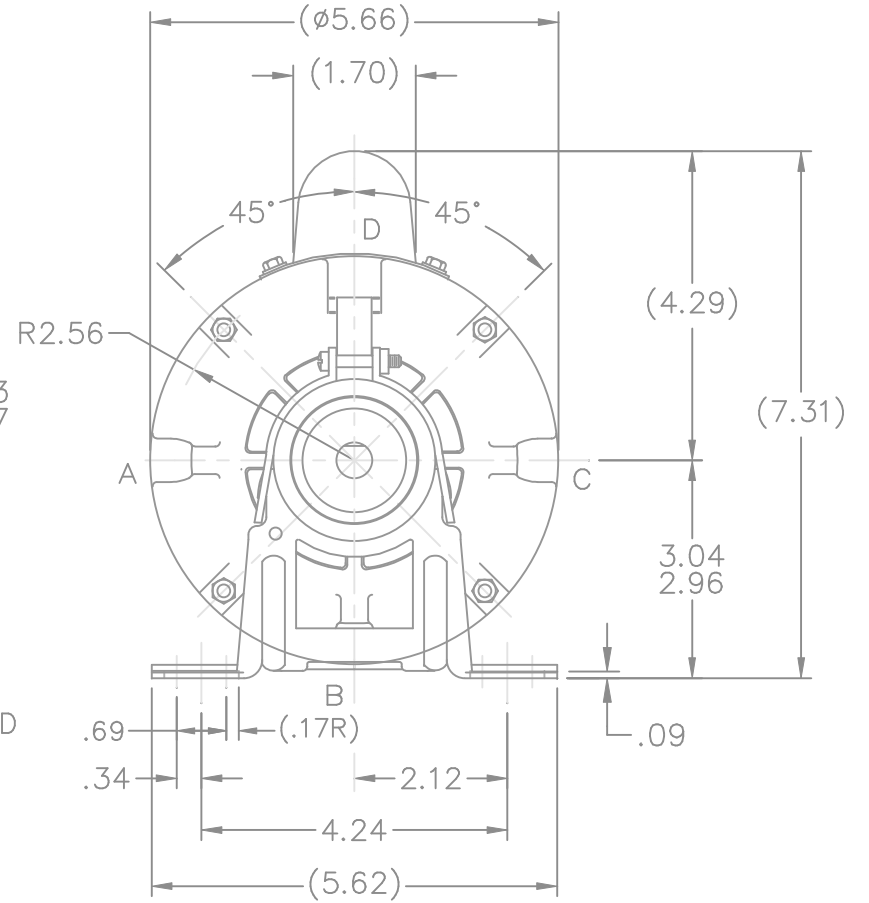
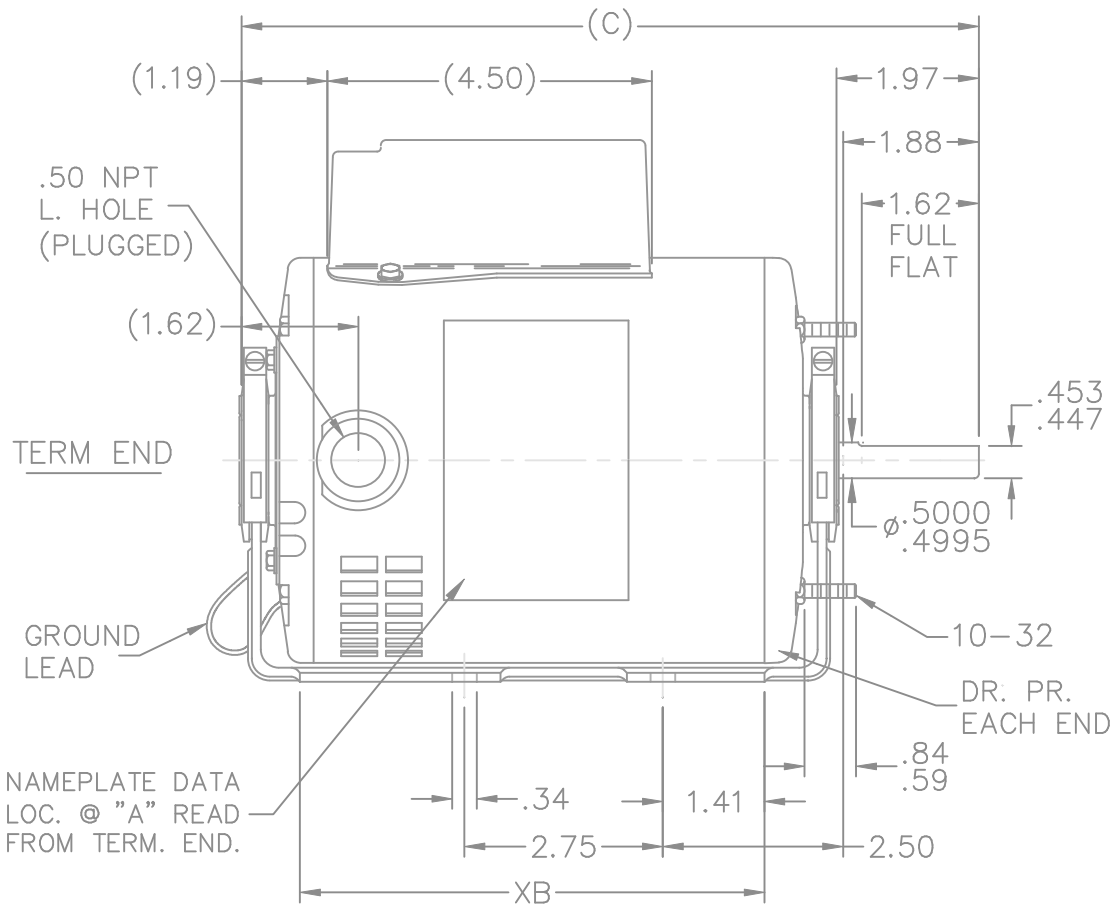

DASH	FR.	C	XB
550	48	9.47	5.69
575	48	9.72	5.94
625	48	10.22	6.44

				TOLERANCES UNLESS SPECIFIED			DRAWN DD 05-11-1993				
				DEC.	INCHES		CHK ML 05-12-1993	APPD SAT 05-12-1993			
6	UPDATED DRAWING	TJW	04/27/2007	.X	±.1	TITLE OUTLINE	SCALE 3=8				
5	REDRAWN IN AUTOCAD	TAT	09-01-2004	ML	.XXX ±.005		REF	FMF			
4	REDRAWN ON CADD	4031395	DD 05-17-1993	.XXXX	±.0005	MAT'L.	PREV				
NO.	REVISION	BY & DATE	CHK	ANG	±'30"	FINISH	SIZE	DRAWING NO.	PAGE	OF	REV.
			RFP			CAD FILE ss79620	A	SS79620			6
			DIST	WP							

THIS DRAWING IN DESIGN AND DETAIL IS OUR PROPERTY AND MUST NOT BE USED EXCEPT IN CONNECTION WITH OUR WORK ALL RIGHTS OF DESIGN AND INVENTION ARE RESERVED THIS IS AN ELECTRONICALLY GENERATED DOCUMENT - DO NOT SCALE THIS PRINT

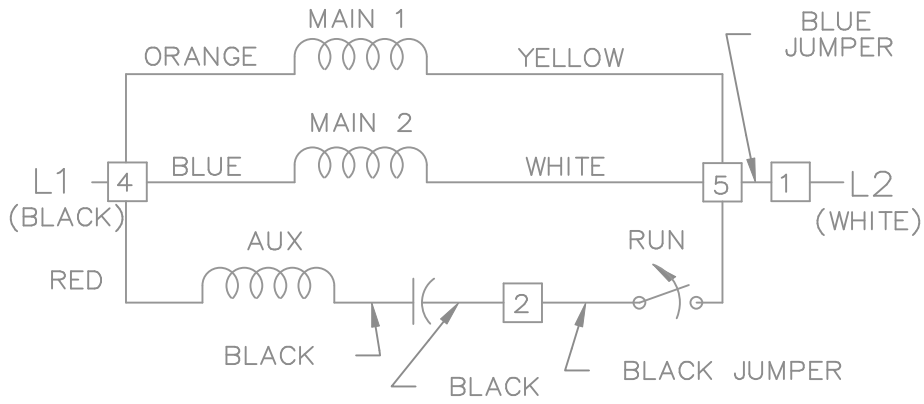

LOW VOLTAGE

DUAL VOLTAGE CAPACITOR START REVERSIBLE ON TERM BOARD NO OVERLOAD PROTECTION

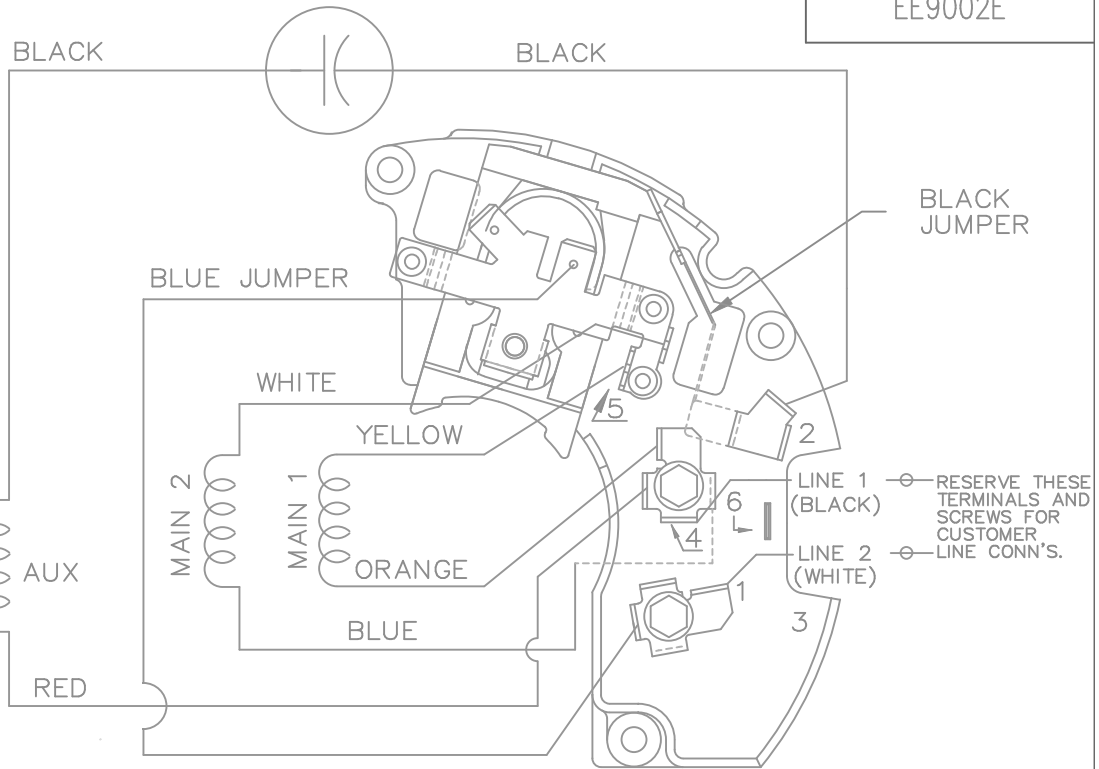

VIEWING TERM END

LOW VOLTAGE CCW ROTATION SHOWN

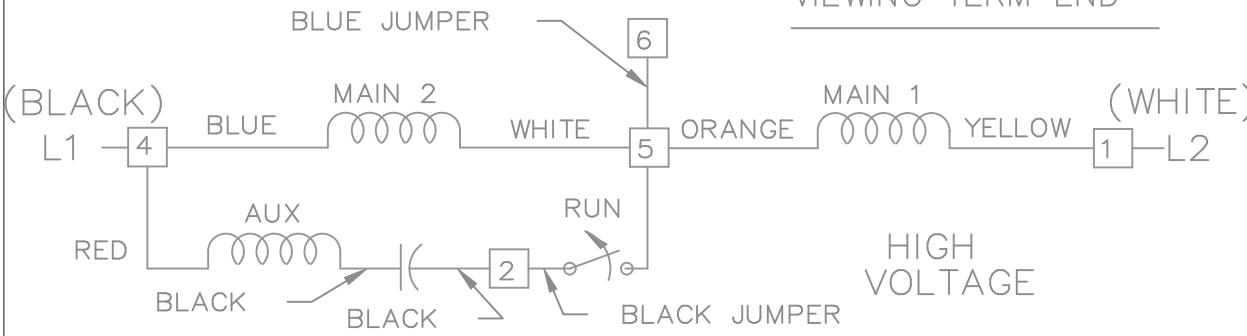

HIGH VOLTAGE

FOR HIGH VOLTAGE:  
CONNECT BLUE TERM 1 TO TERM 6,  
CONNECT YELLOW TERM 5 TO TERM 1,  
CONNECT ORANGE TERM 4 TO TERM 5.

TO REVERSE ROTATION EITHER VOLTAGE INTERCHANGE RED LEAD WITH BLACK LEAD

		TOLERANCES UNLESS SPECIFIED			DRAWN ML 02-02-1988 CHK GK 02-15-1988 APPD DRN 02-24-1988
05	COLOURS ADDED TO L1,L2	RP	12/10/2008		DEC. INCHES
04	WHITE LEAD LOCATED UNDER BKY DATE	BLR	09/13/99	.X ±.1	REF EE9002E-LE
	CODE APPR. 6K AND PRIOR CN 28441			.XX ±.02	FMF
03	REVISED LINE 2 LOCATION CN 6427	RM	01/28/1991	.XXX ±.005	PREV
02	ADDED CUSTOMER CONN. NOTE CN 6011	BW	08/03/1989	.XXXX ±.0005	
NO.	REVISION	BY & DATE	CHK	ANG ±7'30"	
THIS DRAWING IN DESIGN AND DETAIL IS OUR PROPERTY AND MUST NOT BE USED EXCEPT IN CONNECTION WITH OUR WORK ALL RIGHTS OF DESIGN AND INVENTION ARE RESERVED THIS IS AN ELECTRONICALLY GENERATED DOCUMENT - DO NOT SCALE THIS PRINT				RFP	CAD FILE EE9002E
				DIST WP	SIZE A DRAWING NO. EE9002E PAGE OF 05

CERTIFICATION DATA SHEET

Model#: 48C17D2043 L WINDING#: CE48456 NONE 3  
 CONN. DIAGRAM: A-EE9002E ASSEMBLY: F1 ONLY  
 OUTLINE: A-SS79620-625

TYPICAL MOTOR PERFORMANCE DATA

HP	KW	SYNC. RPM	F.L. RPM	FRAME	ENCLOSURE	KVA CODE	DESIGN
1/3	0.25	1800	1725	48Z	DP	J	NO DESIGN CODE

PH	Hz	VOLTS	FL AMPS	START TYPE	DUTY	INSL	S.F	AMB°C	ELEVATION
1	60	115/208-230	5.8/3.1-2.9	ACROSS THE LINE	CONTINUOUS	B3	1.35	40	3300

FULL LOAD EFF: 64	3/4 LOAD EFF: 61.4	1/2 LOAD EFF: 54.7	GTD. EFF	ELEC. TYPE	NO LOAD AMPS
FULL LOAD PF: 60	3/4 LOAD PF: 54.5	1/2 LOAD PF: 43.9	0	CAP START IND RUN	4.2 / 2.1

F.L. TORQUE	LOCKED ROTOR AMPS	L.R. TORQUE	B.D. TORQUE	F.L. RISE°C
16 LB-FT	21.4 / 10.7	28.9 LB-FT 181	38 LB-FT 238	-

SOUND PRESSURE @ 3 FT.	SOUND POWER	ROTOR WK^2	MAX. WK^2	SAFE STALL TIME	STARTS /HOUR	APPROX. MOTOR WGT
- dBA	- dBA	- LB-FT^2	- LB-FT^2	- SEC.	-	- LBS.

\*\*\* SUPPLEMENTAL INFORMATION \*\*\*

DE BRACKET TYPE	ODE BRACKET TYPE	MOUNT TYPE	ORIENTATION	SEVERE DUTY	HAZARDOUS LOCATION	DRIP COVER	SCREENS	PAINT
STANDARD	STANDARD	RESILIENT RING-EXTENDED STUDS	HORIZONTAL	FALSE	NONE	FALSE	NONE	GRAY (POWDER)

BEARINGS		GREASE	SHAFT TYPE	SPECIAL DE	SPECIAL ODE	SHAFT MATERIAL	FRAME MATERIAL
DE	OPE						
BALL	BALL	MULTEMP SRL	SGL SPL EXT	0.500 x 1.88 IN SEF WITH 1.62 IN FULL FLAT	NONE	1144 STRESSPROOF (C-223)	ROLLED STEEL
6203	6203						

THERMO-PROTECTORS				THERMISTORS	CONTROL	SPACE /n HEATERS
THERMOSTATS	PROTECTORS	WDG RTDs	BRG RTDs			
NONE	NOT	NONE	NONE	NONE	FALSE	NONE VOLTS

If Inverter equals NONE, contact factory for further information

\*  
N  
O  
T  
E  
S  
\*

INVERTER TORQUE: NONE
INV. HP SPEED RANGE: NONE
ENCODER: NONE
NONE NONE
NONE NONE PPR
BRAKE: NONE NONE
NONE P/N NONE
NONE NONE
NONE FT-LB NONE V NONE Hz

Uncontrolled Copy

\*\* Subject to change without notice.