

# PRODUCT INFORMATION PACKET

Modal No: 5KCR48TN8062  
Catalog No: C194  
3,3450,DP,145T,1/60/115/230  
Open Drip Proof (ODP)



Regal and Marathon are trademarks of Regal Beloit Corporation or one of its affiliated companies.  
©2017 Regal Beloit Corporation, All Rights Reserved. MC017097E



## Nameplate Specifications

Output HP	<b>3 Hp</b>	Output KW	<b>2.24 kW</b>
Frequency	<b>60 Hz</b>	Voltage	<b>115/230 V</b>
Current	<b>29.4,14.7 A</b>	Speed	<b>3450 rpm</b>
Service Factor	<b>1.15</b>	Phases	<b>1</b>
Efficiency	<b>78.5 %</b>	Duty	<b>CONT</b>
Insulation Class	<b>B</b>	KVA Code	<b>J</b>
Frame	<b>145T</b>	Enclosure	<b>DP</b>
Overload Protector	<b>N/R</b>	Ambient Temperature	<b>40 °C</b>
Drive End Bearing Size	<b>6205</b>	Opp Drive End Bearing Size	<b>6203</b>
UL	<b>Recognized</b>	CSA	<b>Yes</b>
CE	<b>N</b>		

## Technical Specifications

Electrical Type	<b>Capacitor Start Capacitor Run(CSCR)</b>	Starting Method	<b>SM</b>
Poles	<b>2</b>	Rotation	<b>CCW/CW</b>
Mounting	<b>WB</b>	Motor Orientation	<b>ANY</b>
Drive End Bearing	<b>BALL</b>	Opp Drive End Bearing	<b>BALL</b>
Frame Material	<b>Rolled Steel</b>	Overall Length	<b>13.13 in</b>
Frame Length	<b>8.43 in</b>	Shaft Diameter	<b>0.88 in</b>
Shaft Extension	<b>2.25 in</b>		

52A109637

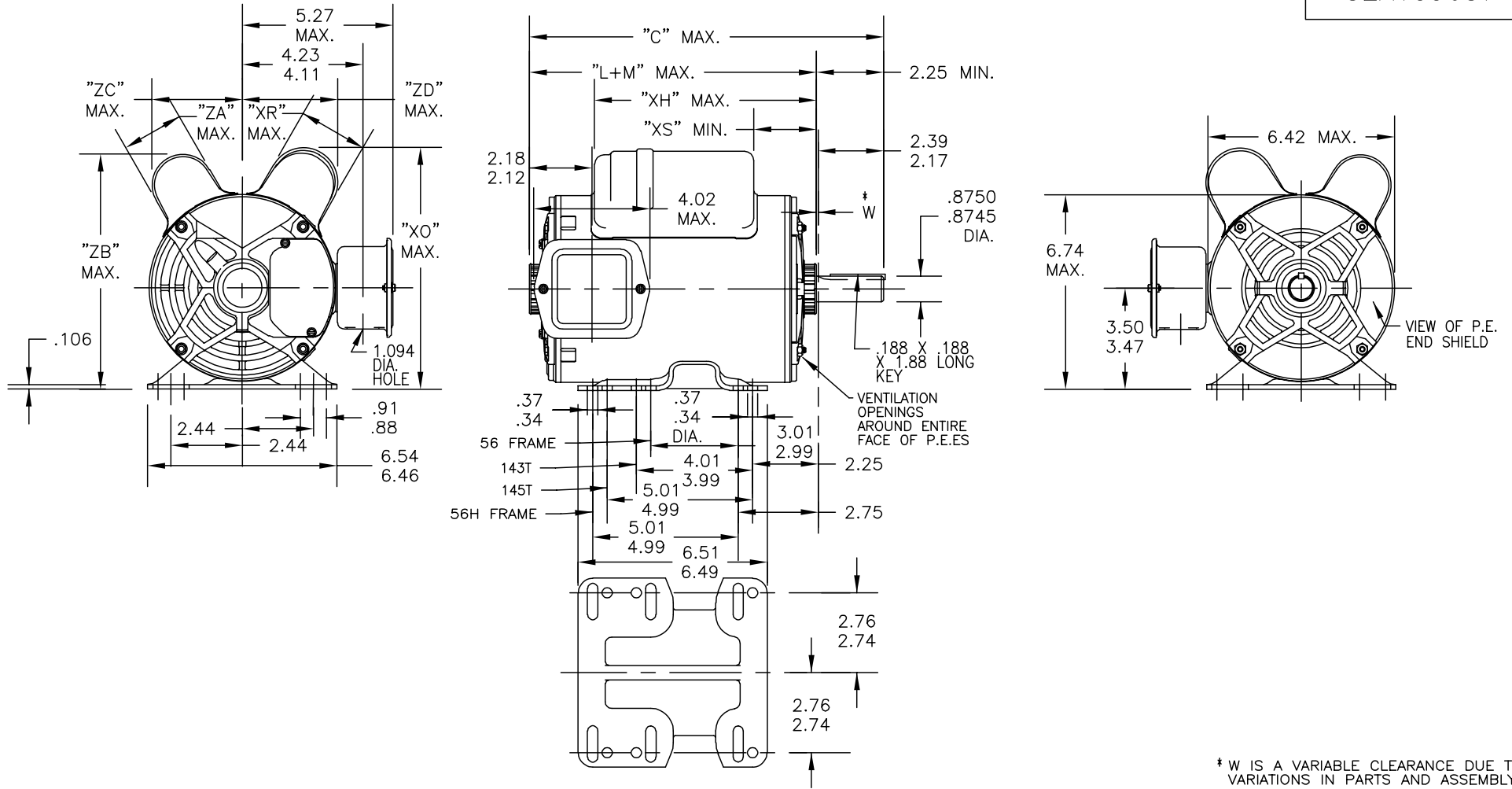

\* W IS A VARIABLE CLEARANCE DUE TO VARIATIONS IN PARTS AND ASSEMBLY

ALL DIMENSIONS ARE IN INCHES

2	KCR	48	143T 145T	13.13	10.76	7.76	7.81	1.60	2.01	2.40	8.40	3.38	2.86	8.43
1	KCR	49	143T 145T	14.33	11.96	8.30	8.78	2.72	2.61	2.10	8.16	3.14	3.43	9.63
P	TYPE	RBC SIZE	NEMA FR.	"C"	"L+M"	"XH"	"XO"	"XR"	"XS"	"ZA"	"ZB"	"ZC"	"ZD"	MIN. SHELL

				TOLERANCES UNLESS SPECIFIED		<b>REGAL-BELOIT CORPORATION</b>		DRAWN M.D.P 06/22/94	
				DEC.	INCHES			CHK	
				.X	±0.1			APPD M.D.P 06/22/94	
4	REDRAWN IN DRAFT SIGHT NO CHANGES	GR	10/16/12	PKG	.XX	±0.02	TITLE		SCALE 1=1
3	CHG TO RBC FORMAT PER ISO5-1777	SD	03/22/06		.XXX	±0.005	OUTLINE		REF
2	REV. O.E. E.S. PER TI95-22196.	MDP	10/20/95		.XXXX	±0.0005	DP- WELDED BASE		FMF
NO.	REVISION	BY & DATE	CHK	ANG	±1.0	FINISH			PREV

THIS DRAWING IN DESIGN AND DETAIL IS OUR PROPERTY AND MUST NOT BE USED EXCEPT IN CONNECTION WITH OUR WORK ALL RIGHTS OF DESIGN AND INVENTION ARE RESERVED THIS IS AN ELECTRONICALLY GENERATED DOCUMENT - DO NOT SCALE THIS PRINT

RFP	CAD FILE	52A109637	SIZE	DRAWING NO.	REV.
DIST			A	52A109637	4

